

NEW JERSEY SPRING SHOW

Showmanship (walk trot)

Show Date: 2022

Fr.

www.HorseShowPatterns.com

www.HorseShowPatterns.com

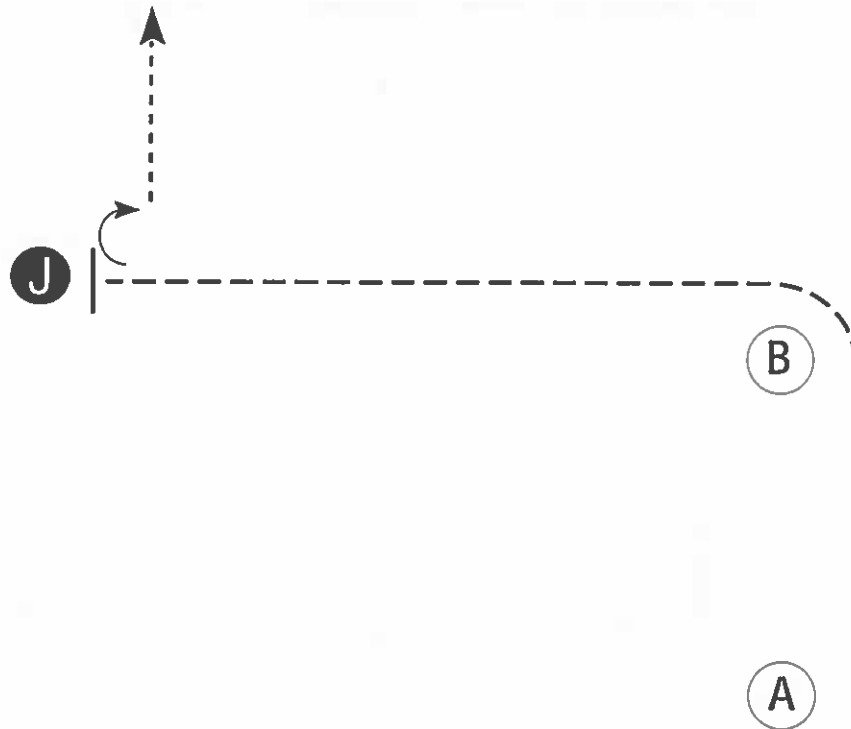

Be ready at A.

1. Walk from A to B.
2. At B, trot to judge.
3. Stop and set up for inspection.
4. When dismissed, turn 90 degrees and walk away from judge.
5. Follow the instructions of your ring steward.

Walk	-----
Trot	- - - - -
Back	←←←←← ←←←←←
Marker	⊙ B
Judge	● J

[SWT-11]

Pattern Provided by:

The Judges

NEW JERSEY SPRING SHOW

Showmanship (all novice)

Show Date: 2022

Fri

w w w . H o r s e S h o w P a t t e r n s . c o m

w w w . H o r s e S h o w P a t t e r n s . c o m

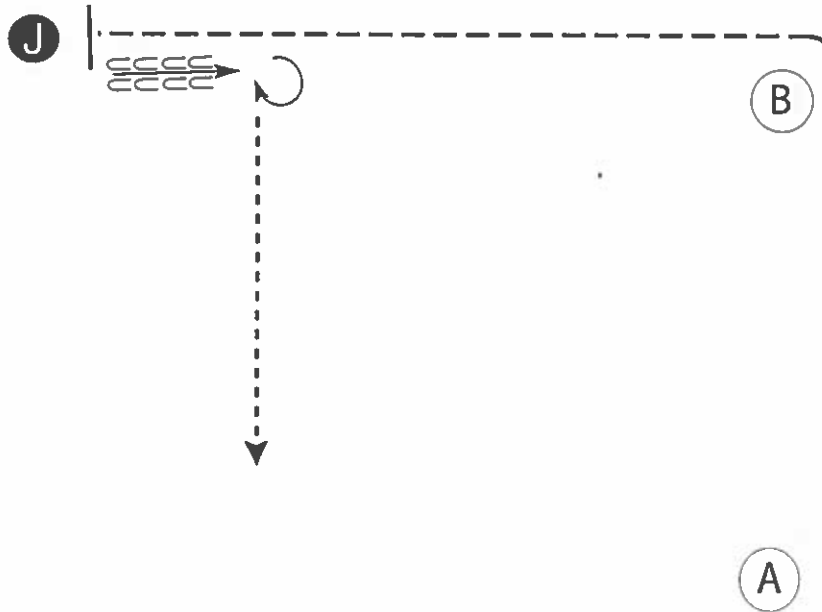

Be ready at A.

1. Walk to B.
2. Trot around B and to judge.
3. Stop and set up for inspection.
4. When dismissed, back one horse length.
5. Turn 270 degrees and walk straight off.

Walk	-----
Trot	- . - . - .
Back	← — — — — —
Marker	Ⓚ
Judge	ⓐ

[S/1-23]

Pattern Provided by:

The Judges

NEW JERSEY SPRING SHOW

Hunt Seat Equitation (walk trot)

Fri

Show Date: 2022

www.HorseShowPatterns.com

www.HorseShowPatterns.com

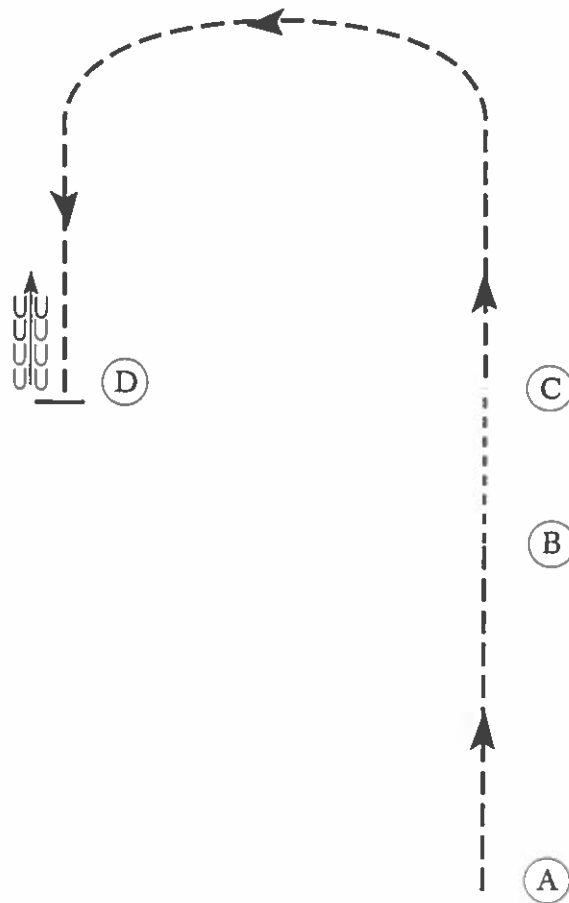

Be ready at A.

1. Posting trot on the left diagonal from A to B.
2. Walk from B to C.
3. Posting trot on the right diagonal from C to D.
4. Stop and back approximately one horse length at D.

Exit at a sitting trot.

Walk	-----
Trot	- - - - -
Extended Trot	— — — —
Canter	—————
Leg Yield	
Lead Change	— / —
Back	←←←←←
Marker	Ⓚ
Sidepass	← — — — ←
Hand Gallop	—————

[HSE/WT-20]

Pattern Provided by:

The Judges

NEW JERSEY SPRING SHOW

Hunt Seat Equitation (all novice)

fri

Show Date: 2022

w w w . H o r s e S h o w P a t t e r n s . c o m

w w w . H o r s e S h o w P a t t e r n s . c o m

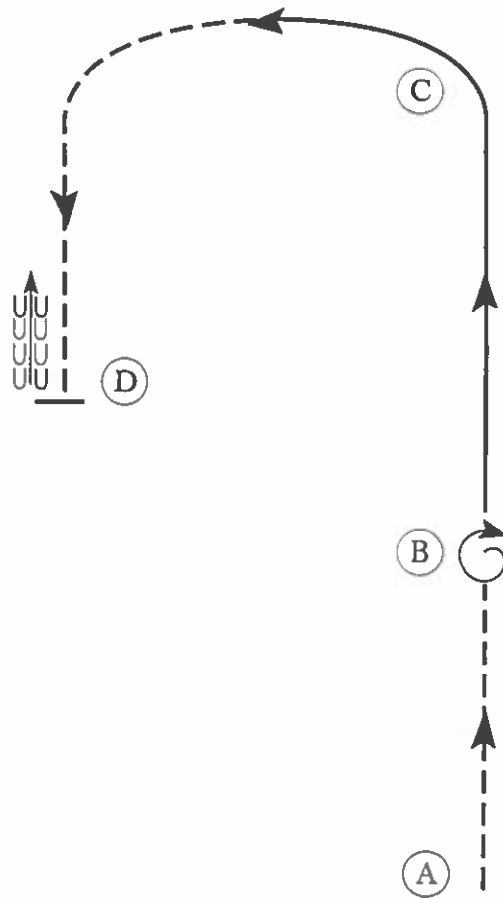

Be ready at A.

1. Posting trot on the left diagonal from A to B.
2. Stop at B and turn on the forehand 360 degrees to the right.
3. At B, canter on the right lead.
4. At the top of the arc, transition to the posting trot to D.
5. Stop and back approximately one horse length at D.

Exit at a sitting trot.

Walk	-----
Trot	- - - - -
Extended Trot	-----
Canter	-----
Leg Yield	
Lead Change	↘
Back	←←←←←
Marker	Ⓚ
Sidepass	←←←←←
Hand Gallop	-----

[HSE/2-22]

Pattern Provided by:

The Judges

NEW JERSEY SPRING SHOW

Hunt Seat Equitation (all youth, select, and amateur)

Fri

Show Date: 2022

www.HorseShowPatterns.com

www.HorseShowPatterns.com

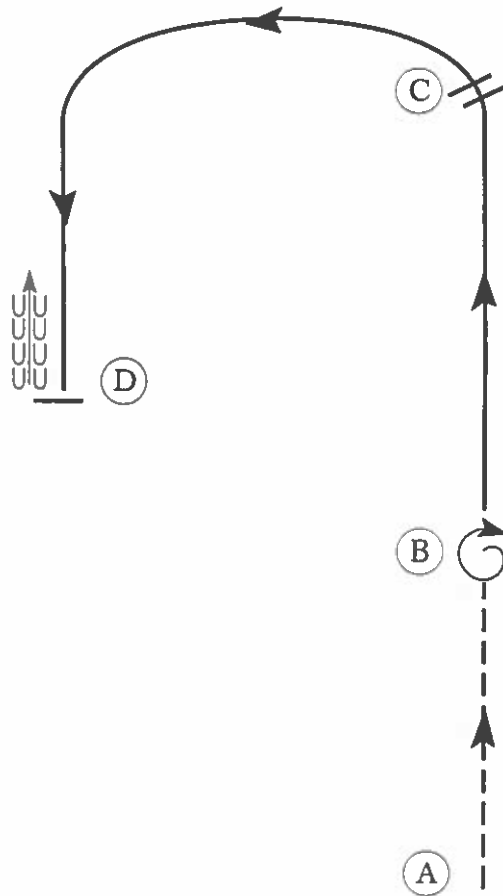

Be ready at A.

1. Posting trot on the left diagonal from A to B.
2. Stop at B and turn on the forehand 360 degrees to the right.
3. Canter on the right lead from B to C.
4. Change leads at C.
5. Canter on the left lead to D.
6. Stop and back approximately one horse length at D.

Exit at a sitting trot.

Walk	-----
Trot	- - - - -
Extended Trot	— — — — —
Canter	—————
Leg Yield	
Lead Change	— / —
Back	←←←←←
Marker	Ⓚ
Sidepass	←←←←←
Hand Gallop	— — — — —

[HSE/3-22]

Pattern Provided by:

The Judges

NEW JERSEY SPRING SHOW

Western Horsemanship (walk trot)

Show Date: 2022

fri

w w w . H o r s e S h o w P a t t e r n s . c o m

w w w . H o r s e S h o w P a t t e r n s . c o m

1. Walk A to B
2. At B jog to D
3. At D stop and back 4 steps.

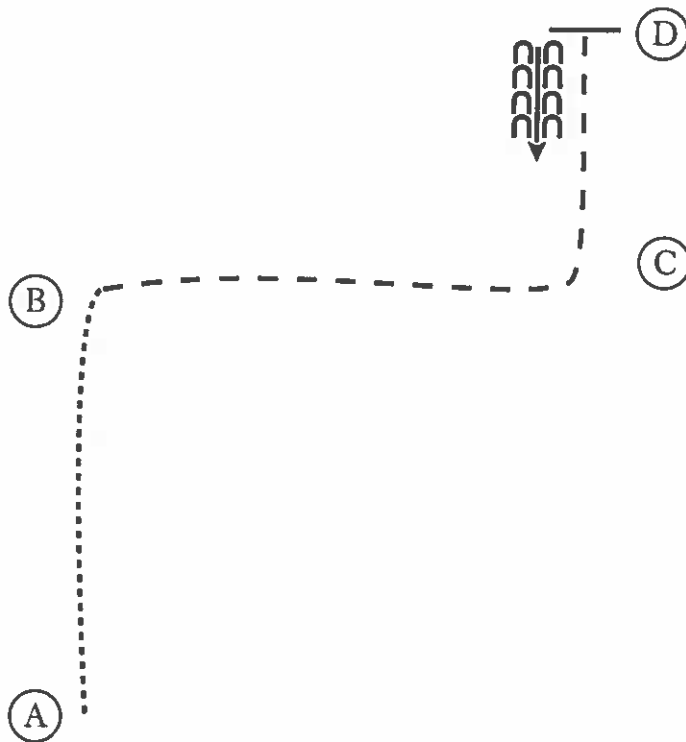

Walk
Jog	-----
Extended Jog	—————
Lope	—————
Leg Yield	
Lead Change	///
Back	←←←←
Marker	(B)
Sidepass	←←←←

[WH/WT-2]

Pattern Provided by:

The Judges

NEW JERSEY SPRING SHOW

Western Horsemanship (all novice)

Show Date: 2022

Fri

www.HorseShowPatterns.com

www.HorseShowPatterns.com

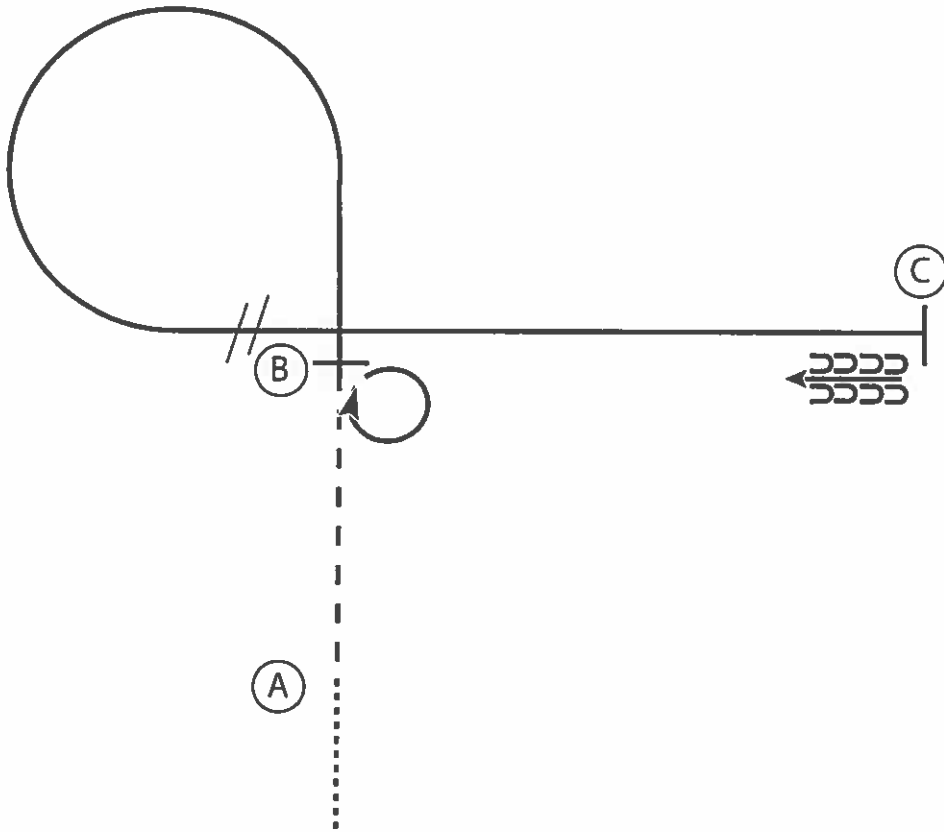

1. Walk to A
2. At A jog to B
3. Stop at B and perform a 360 degree turn to the right
4. Lope a circle to the left
5. At B perform a lead change and continue to C
6. At C stop and back 5 steps

Walk
Jog	-----
Extended Jog	-----
Lope	—————
Leg Yield	
Lead Change	///
Back	←←←←←
Marker	(B)
Sidepass	- - - - ->

[WH/2-10]

Pattern Provided by:

The Judges

NEW JERSEY SPRING SHOW

Western Horsemanship (all youth, select, and amateur)

Show Date: 2022

Fri

www.HorseShowPatterns.com

www.HorseShowPatterns.com

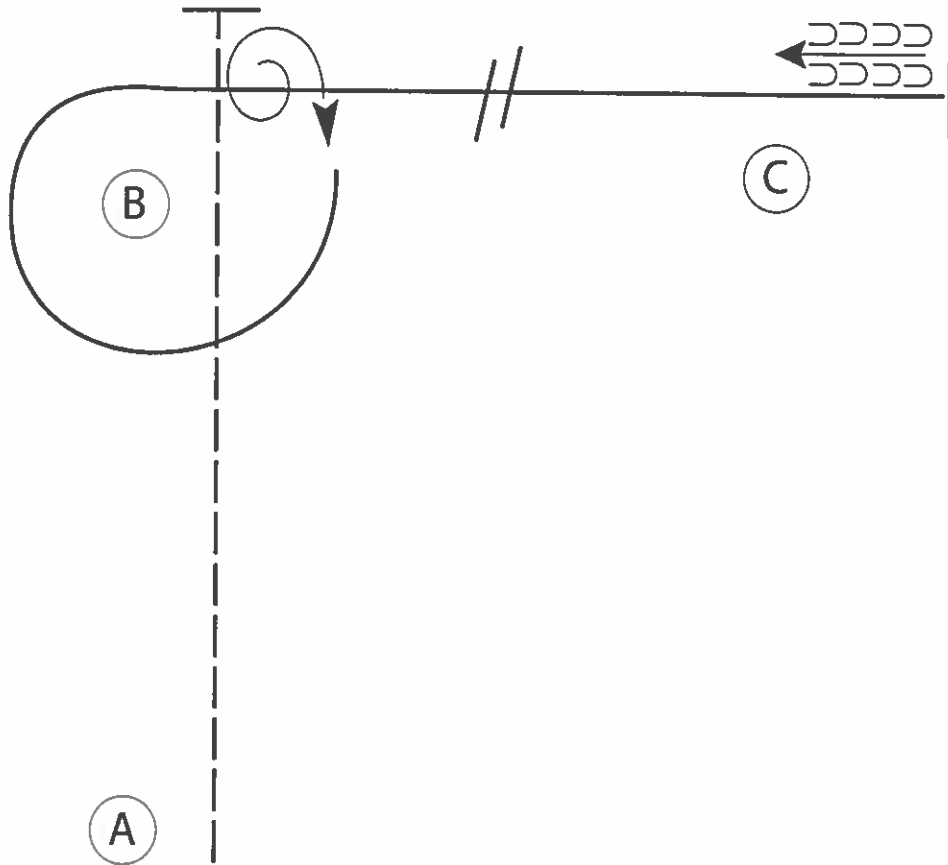

Be ready at A.

1. Perform an extended jog from A past B
2. Stop past B and perform a 540 degree turn to the right.
3. Lope on the right lead around B and continue towards C.
4. Half way between B and C perform a simple lead change.
5. Continue to lope past C and stop.
6. Back to C.

Follow the instructions of your ring steward.

Walk
Jog	-----
Extended Jog	-----
Lope	—————
Leg Yield	
Lead Change	—/—
Back	←←← ←←←
Marker	(B)
Sidepass	←←←

[WH/3-6]

Pattern Provided by:

The Judges

NJQHA
THURS. MAY 12

TRAIL:
SMALL FRY
WALK JOG

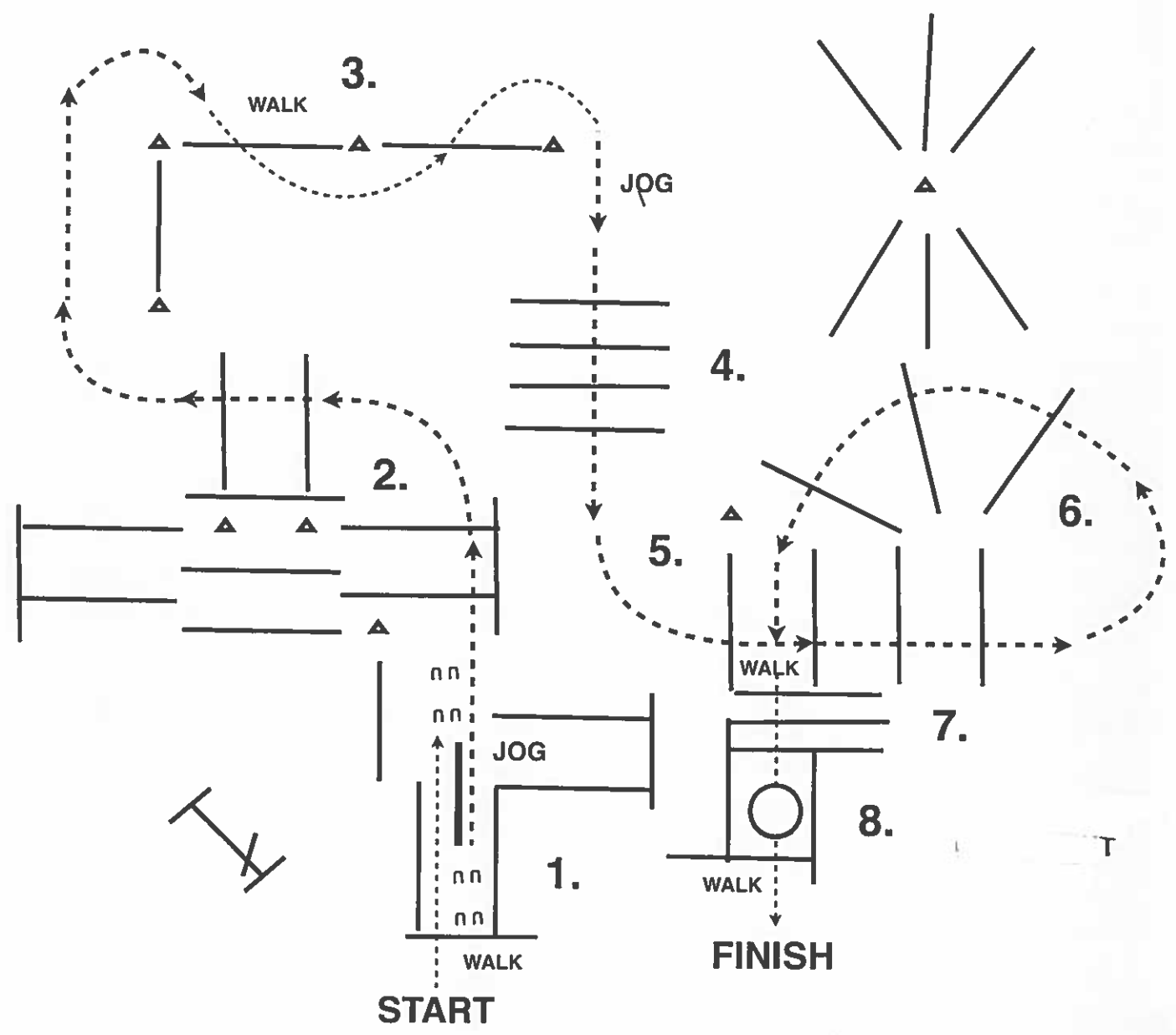

1. WALK OVER POLE, WALK UP CHUTE, STOP AND BACK INTO CHUTE.
2. JOG OUT CHUTE, JOG OVER POLES.
3. WALK OVER POLES, WALK THRU SERPENTINE.
4. JOG OVER POLES
5. JOG OVER POLES
6. JOG OVER POLES
7. WALK OVER POLES
8. WALK INTO BOX, EXECUTE A 360 TURN EITHER WAY, WALK OUT BOX.

NJOHA
THURS. MAY 12

TRAIL:
GREEN AND YOUTH
NOVICE YOUTH
NOVICE AMATEUR

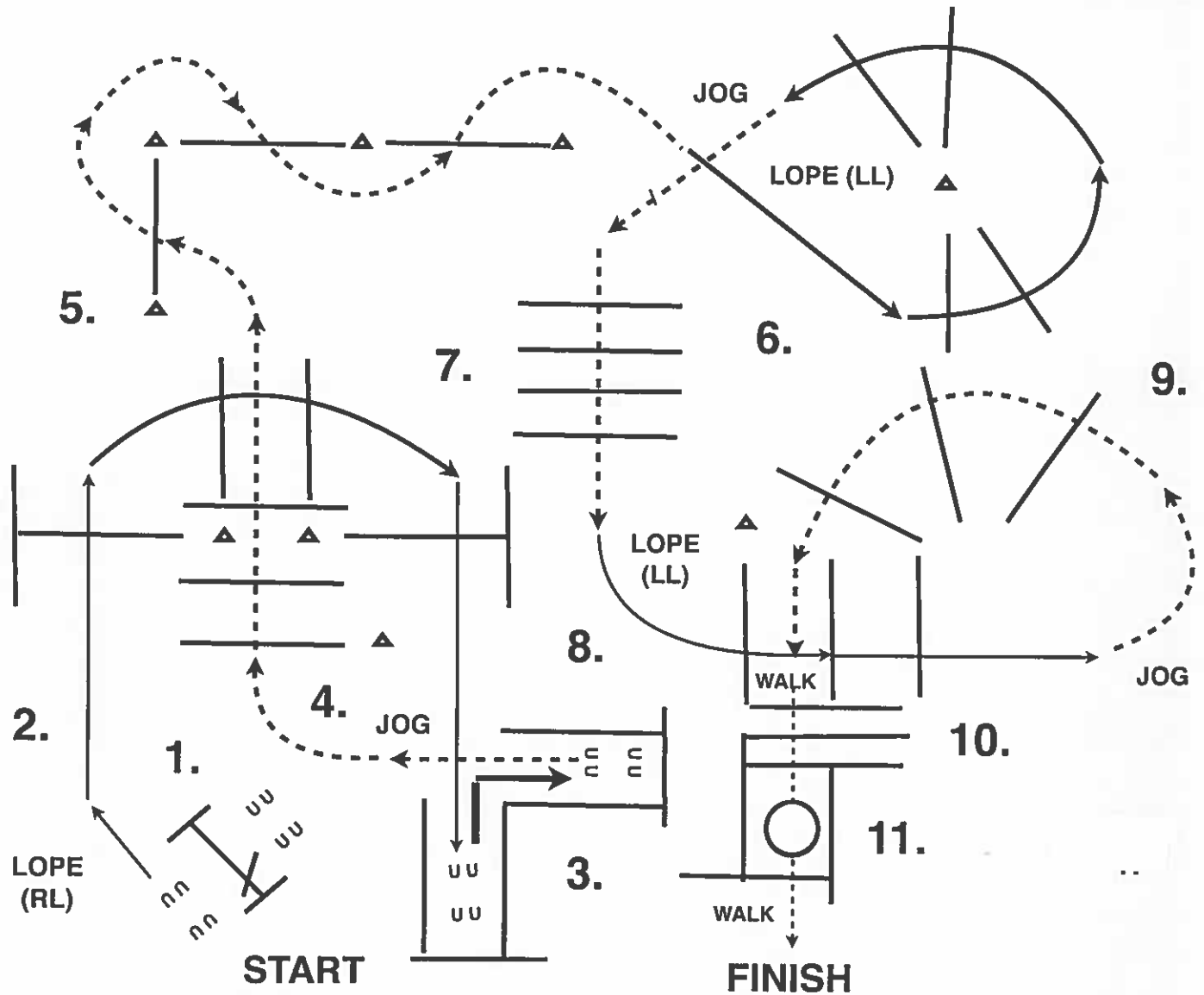

1. GATE: RH OPEN WALK OVER POLE, CLOSE GATE.
2. LOPE OVER POLES (RL), LOPE INTO CHUTE.
3. BACK THRU "L", JOG OUT CHUTE.
4. JOG OVER POLES.
5. JOG THRU SERPENTINE, JOG OVR POLES.
6. LOPE OVER POLES (LL).
7. BREAK TO JOG, JOG OVER POLES.
8. LOPE OVER POLES (LL)
9. BREAK TO JOG, JOG OVER POLES.
10. STOP OR BREAK TO THE WALK, WALK OVER POLES, WALK INTO BOX.
11. EXECUTE A 360 TURN EITHER DIRECTION, WALK OUT BOX.

NJCHA
Thurs MAY 12

TRAIL:
SENIOR AND JUNIOR
AMATEUR AND SELECT

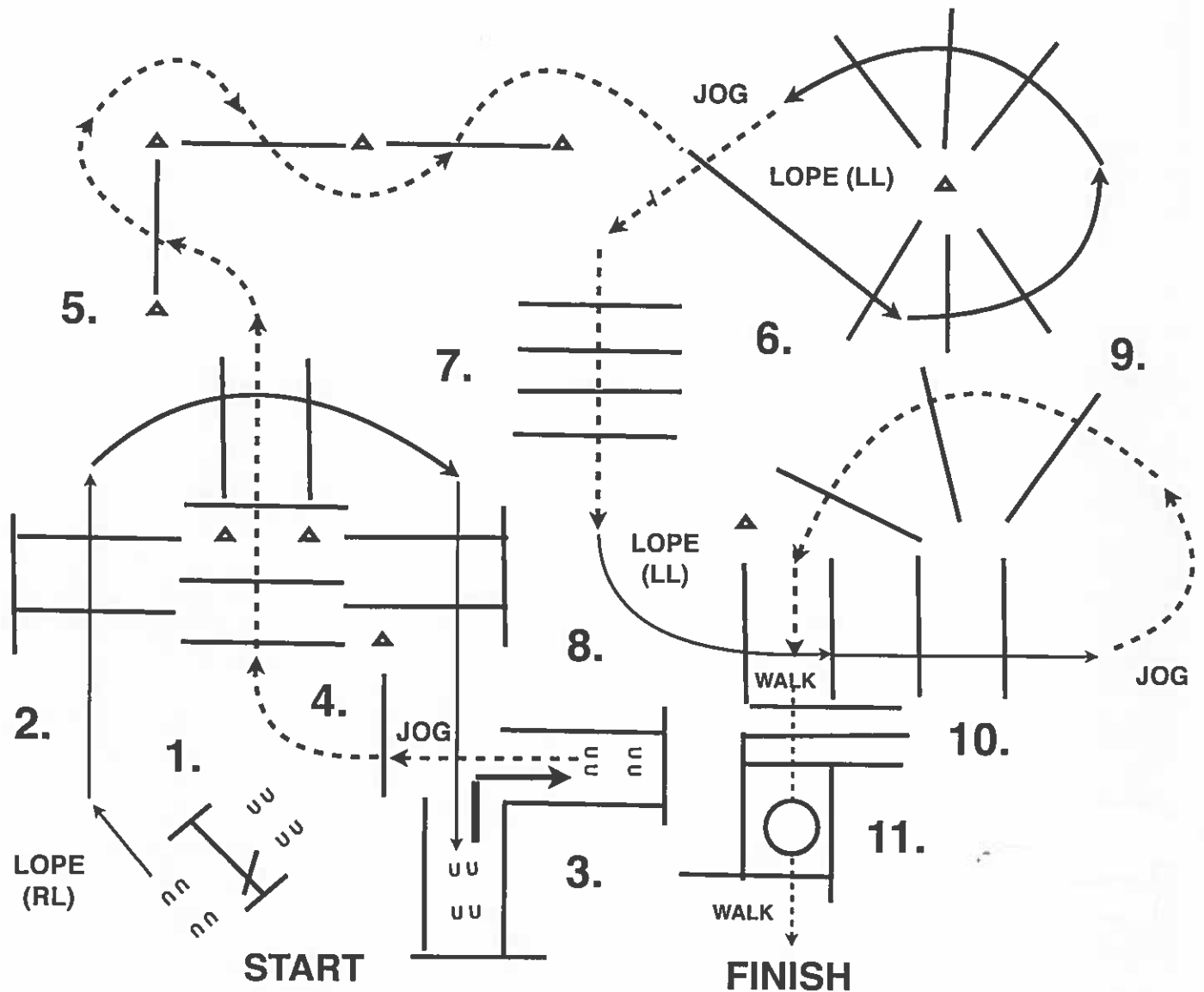

1. GATE: RH OPEN WALK OVER POLE, CLOSE GATE.
2. LOPE OVER POLES (RL), LOPE INTO CHUTE.
3. BACK THRU "L", JOG OUT CHUTE.
4. JOG OVER POLES.
5. JOG THRU SERPENTINE, JOG OVR POLES.
6. LOPE OVER POLES (LL).
7. BREAK TO JOG, JOG OVER POLES.
8. LOPE OVER POLES (LL)
9. BREAK TO JOG, JOG OVER POLES.
10. STOP OR BREAK TO THE WALK, WALK OVER POLES, WALK INTO BOX.
11. EXECUTE A 360 TURN EITHER DIRECTION, WALK OUT BOX.

REINING PATTERN 2

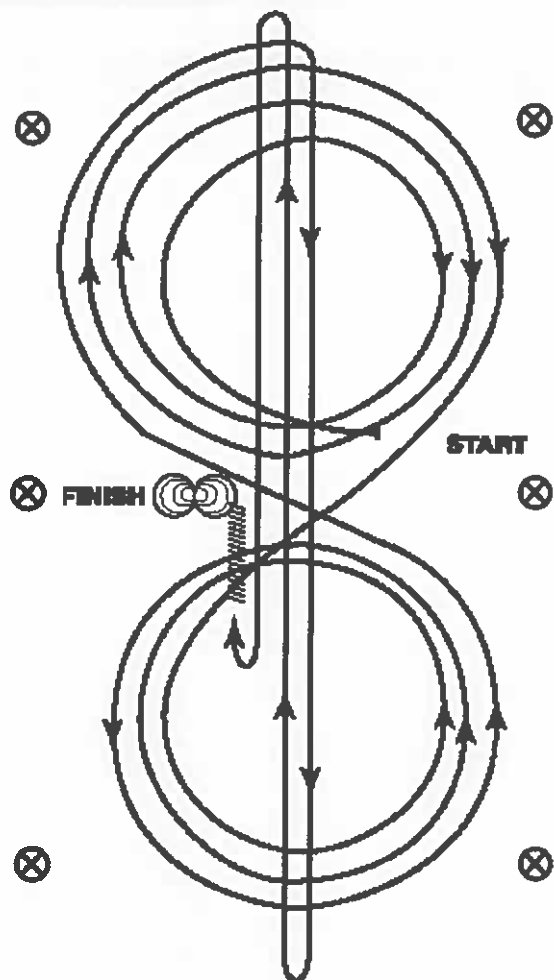

Horse must walk or stop prior to starting pattern.

Beginning at the center of the arena facing the left wall or fence.

1. Beginning on the right lead, complete three circles to the right: the first circle small and slow; the next two circles large and fast. Change leads at the center of the arena.
2. Complete three circles to the left: the first circle small and slow; the next two circles large and fast. Change leads at the center of the arena.
3. Continue around previous circle to the right. At the top of the circle, run down the middle to the far end of the arena past the end marker and do a right rollback - no hesitation.
4. Run up the middle to the opposite end of the arena past the end marker and do a left rollback - no hesitation.
5. Run past the center marker and do a sliding stop. Back up to the center of the arena or at least 10 feet (3 meters). Hesitate.
6. Complete four spins to the right.
7. Complete four spins to the left. Hesitate to demonstrate the completion of the pattern.

Rider may drop bridle to the designated judge.

RANCH RIDING - PATTERN 9

LEGEND

.....	Walk
... ..	Extended Walk
- - -	Trot
- - - -	Extended Trot
— — —	Lope
— — — —	Extended Lope
//////	Back
\\	Lead Change

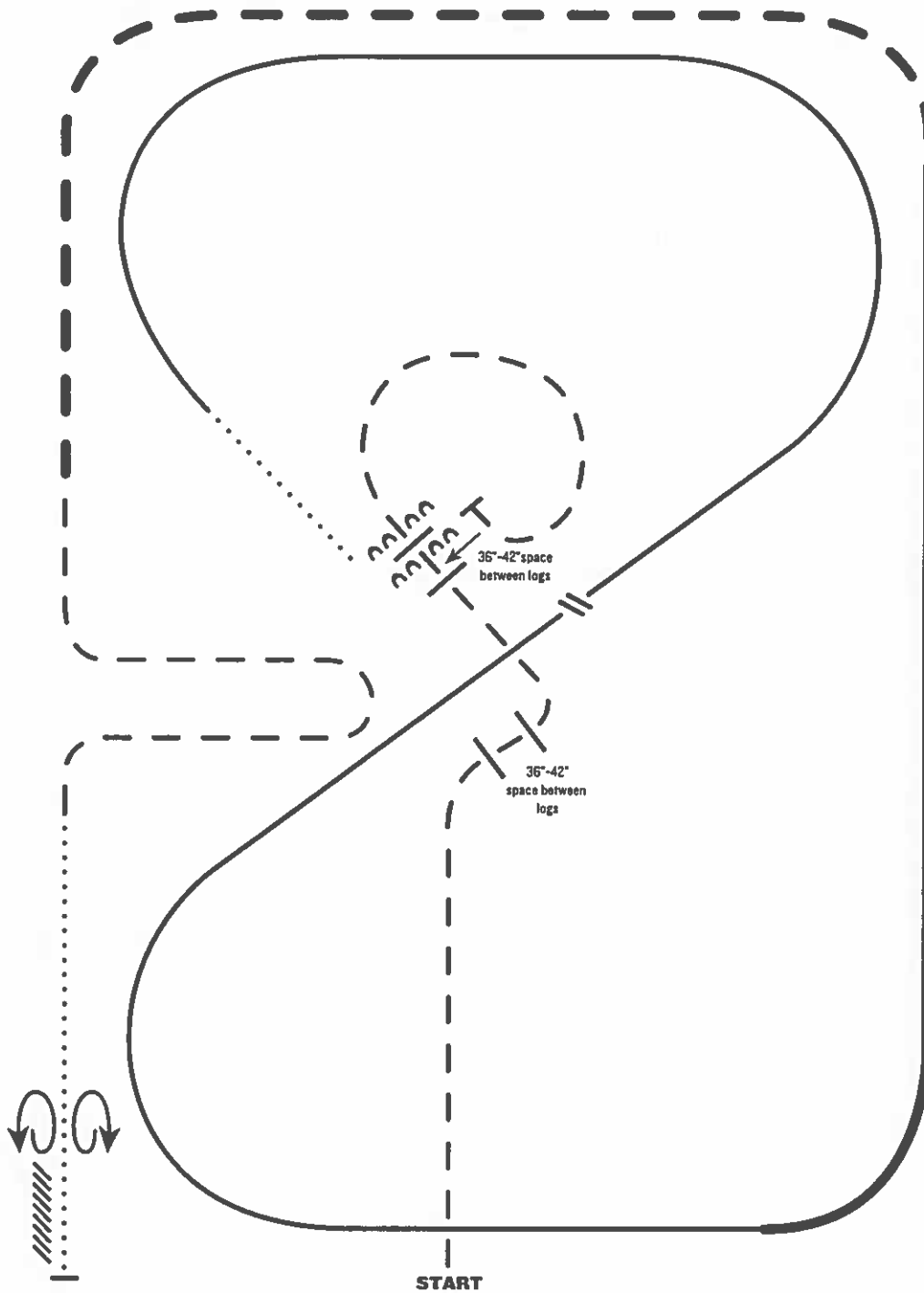

Thurs

1. Trot
2. Trot over two sets of logs
3. Trot circle, stop and side pass left over log
4. Walk
5. Lope right lead
6. Change leads (simple or flying)
7. Lope left lead
8. Extended lope left lead
9. Extended trot
10. Trot
11. Walk
12. Stop and back
13. 360° turn each direction (either direction 1st) (L-R or R-L)

Note: The drawn description of this pattern is only intended for the general depiction of the pattern. Exhibitors should utilize the arena space to best exhibit their horses.